

**Primus danmark.dk**

**BRUGSANVISNING TIL VORES ELEKTRISKE TRÆKSPRIL 12 VOLT**

# Electric Winch

(Permanent magnetic motor)

2000lbs/2500lbs/3000lbs

## Assembly & Operating Instructions

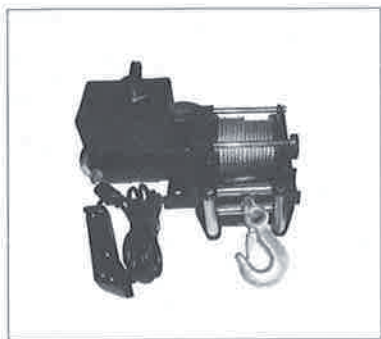

WIRED REMOTE CONTROL

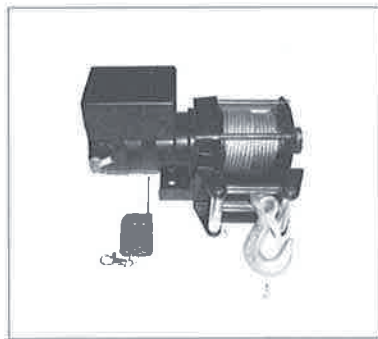

WIRELESS REMOTE CONTROL

## INTRODUCTION

Thank you for purchasing a 2000lbs/2500lbs/3000lbs winch from our company. Please read and understand this Owner's Manual prior to installing and using your winch.

## GENERAL DESCRIPTION

Each winch is equipped with a permanent magnet motor and is designed for intermittent duty general use. The winches are not designed to be used in industrial or hoisting applications and the manufacturer does not warrant it to be suitable for such use. Free spool Clutch is operated by a pull and turn knob winch disengages the gearbox to allow the wire rope to be pulled out without using electric power. A tension plate reduces backlash and snarling when pulling out the wire rope.

## GENERAL SAFETY INFORMATION

1. Never lift people or hoist loads over people. Do not lift items vertically. The winch was designed for horizontal use only.
2. **DO NOT OVERLOAD. FOR LOADS OVER 1000LBS(454KGS), WE RECOMMEND THE USE OF THE OPTIONAL PULLEY BLOCK TO DOUBLE LINE THE WIRE ROPE(Figure 1)**
3. Do not attempt to prolong pulls at heavy loads. The electric winch is designed for intermittent use only, and should not be used in a constant duty application. The duration of the pulling job should be kept as short as possible. If the Winch motor becomes very hot to touch, stop the Winch and let it cool down for several minutes. Never pull for more than one minute at or near the rated load.
4. **NEVER WINCH WITH LESS THAN 5 TURNS** of wire rope **AROUND THE WINCH DRUM** since the wire rope end fastener may **NOT** withstand full load.
5. **AVOID CONTINUOUS PULLS FROM EXTREME ANGLES** as this will cause the wire rope to pile up on one end of the drum (Figure 2) This can jam the wire rope in the winch, causing damage to the rope or the winch.
6. **BE SURE THE INPUT VOLTAGE BETWEEN THE TERMINALS OF MOTOR IS ALWAYS DC 12V OR DC 24V IN ORDER TO REACH THE MAX RATED LINE PULL DURING THE OPERATION. AND PLEASE NOTE THAT IT ONLY CAN REACH THE MAX RATED LINE PULL BY FIRST LAYER OF CABLE AROUND THE DRUM WHEN PULLING THE LOADS.**

7. **NEVER HOOK THE WIRE ROPE BACK TO ITSELF** because you could damage the wire rope. Use a nylon sling. (Figure 3)
8. Be sure the winch mounted on the vehicle or other object before operation.
9. When moving a load, slowly take up the wire rope slack until it becomes taut. Stop, recheck all winching connections. Be sure the hook is properly seated. If a nylon sling is used, check the attachment to the load.
10. It is a good idea to lay a heavy blanket or jacket over the wire rope near the hook end when pulling heavy loads (Figure 3). If a wire rope failure should occur, the cloth will act as a damper and help prevent the rope from whipping.
11. Do not move your vehicle to assist the winch in pulling the load. The combination of the winch and vehicle pulling together could overload the wire rope and the winch.
12. **NEVER BE ON OR AROUND THE WINCH DRUM WHEN WINCH IS UNDER LOAD. (KEEP AWAY FROM THE WINCH AT LEAST 1.5M DURING THE OPERATION)**
13. **DO NOT CROSS OVER OR UNDER THE WIRE ROPE WHEN THE WINCH IS UNDER LOAD.**
14. When using your winch to move a load, place the vehicle transmission in neutral, set vehicle brake, and chock all wheels. The vehicle engine should be running during winch operation. If considerable winching is performed with the engine off, the battery may be too weak to restart the engine.
15. **NEVER RELEASE FREE SPOOL CLUTCH WHEN THERE IS A LOAD ON THE WINCH.**
16. After operation, please release the load. Do not allow the cable tight any more.
17. Always stand clear of wire rope, hook and winch.
18. **INSPECT WIRE ROPE AND EQUIPMENT FREQUENTLY. A FRAYED WIRE ROPE WITH BROKEN STRANDS SHOULD BE REPLACED IMMEDIATELY. USE ONLY FACTORY APPROVED SWITCHES, REMOTE CONTROLS AND ACCESSORIES. USE HEAVY LEATHER GLOVES WHEN HANDLING WIRE ROPE. DO NOT LET WIRE ROPE SLIDE THROUGH BEAR HANDS.**
19. Keep clear of winch, taut wire rope and hook when operating the winch. Never put your finger through the hook. If your finger should become trapped in the hook, you could lose your finger. Always use the safety pull strap when guiding the wire rope in or out.
20. After operated the winch, re-spool the cable around the drum tightly.

21. **DO NOT OPERATE WINCH WHEN UNDER THE INFLUENCE OF DRUGS, ALCOHOL OR MEDICATION.** Always stay alert during the operation.
23. Use eye and ear protection. Always wear impact safety goggles. Wear a full face shield if you are producing metal filings or wood chips. Wear dust mask or respirator when working around metal, wood, and chemical dusts and mists.
23. **DO NOT MACHINE OR WELD ANY PART OF THE WINCH.** Such alterations may weaken the structural integrity of the winch and could void your warranty.
24. Make some maintenance frequently for the winch.

## INSTALLATION

Correct installation of your winch is required for proper operation.

1. Mount the winch on the vehicle or other object using Screw M8x30, lockwasher, Washer-Flat offered. Other similar screws can be substitutes.  
**WARNING:** This winch must be mounted with the wire rope in the unrewind direction. Improper mounting could damage your winch and void your warranty.
2. Route the two couple of lines from the switch to the motor and battery respectively. Connect the red line to the positive (+) terminal and the green (or black) line to the negative (-) terminal of the 12 volt battery. Connect the rest two lines to the terminal on the motor of the electric winch(Figure 4)
3. Check the direction of the drum turning.  
Pull and turn the clutch knob to the "Off" position (drum can be turned freely). Pull out the cable from the drum then engage the clutch by turning the knob to the "In" position. Push the "cable in" button on the handhel, if the cable is re-Spooling then the connecting is correct. Otherwise please change the line connected to the motor. And repeat the abovementioned operation.

## OPERATION

1. Pull and turn the clutch knob to the "Off" position, so the drum can be turned freely by hand.
2. Grab the cable assembly hook and pull the cable to the desired length by

Safety pull strap. Then attach to the item that is going to be pulled.

**WARNING: CHECK THAT THERE ARE AT LEAST FIVE TURNS OF WIRE ROPE LEFT ON THE DRUM BEFORE OPERATION.**

3. Engage the clutch by turning the clutch knob to the "In" position.

**WARNING: CLUTCH MUST BE FULLY ENGAGED BEFORE WINCHING. NEVER ENGAGE CLUTCH KNOB WHILE DRUM IS TURNING. THE CLUTCH KNOB HAS BEEN ADJUSTED AND PERMANENTLY LOCKED IN PLACE WITH A THREAD LOCKING COMPOUND AT THE FACTORY. DO NOT ATTEMPT TO RE-ADJUST THE KNOB.**

4. Push and hold the "Cable In" button on the handheld and the cable was re-spooled.

Push and hold the "Cable Out" button to reverse directions. Wait until the motor stops before reversing directions.

5. Re-spooling cable after finished operation.

## **MAINTENANCE**

1. Periodically check tightness of mounting bolts and electrical connections. Remove all the dirt or corrosion that may have accumulated on the electrical connections.
2. Do not attempt to disassembly the gearbox. Disassembly will void warranty. Repairs should be done by manufacturer authorized repair centre.
3. The gearbox has been lubricated using high temperature lithium grease at the factory.  
No internal lubrication is required.

## **REPLACE THE WIRE ROPE**

1. Engage the clutch by turning the clutch knob to the "In" position.
2. When inserting the wire rope into the drum, insert it into the correct end of the hold provided (Figure 5). Tighten the set screw securely.
3. Operate the winch and re-spool the wire rope around the drum.

**CAUTION:**

**ALWAYS REPLACE DAMAGED WIRE ROPE WITH MANUFACTURER'S IDENTICAL REPLACEMENT PART.**

**TROUBLESHOOTING**

SYMPTOM	POSSIBLE CAUSE	SUGGESTED ACTION
Motor will not operate, or runs in one direction only	<ul style="list-style-type: none"> <li>-Switch inoperative</li> <li>-Broken wires or bad connection</li> <li>-Defective motor</li> </ul>	<ul style="list-style-type: none"> <li>-Replace switch</li> <li>-Check for poor connections</li> <li>-Replace or repair motor</li> </ul>
Motor runs but drum does not turn	<ul style="list-style-type: none"> <li>-Clutch not engaged</li> </ul>	<ul style="list-style-type: none"> <li>-Engage clutch</li> </ul>
Motor runs but with insufficient power or line speed	<ul style="list-style-type: none"> <li>-Weak battery</li> <li>-Defective motor</li> </ul>	<ul style="list-style-type: none"> <li>-Recharge or replace battery.</li> <li>-Check battery terminals for corrosion. Clean as required.</li> <li>-Check and clean connections</li> <li>-Repair or replace motor</li> </ul>
Motor overheating	<ul style="list-style-type: none"> <li>-Winch running time too long</li> <li>-Defective motor</li> </ul>	<ul style="list-style-type: none"> <li>-Allow winch to cool down periodically</li> <li>-Repair or replace motor</li> </ul>

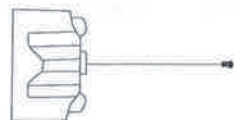

Single Line

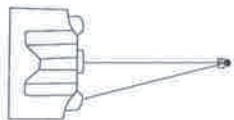

Double Line

**Figure 1**

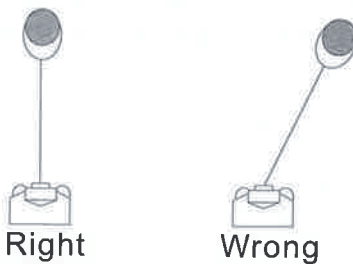

**Figure 2**

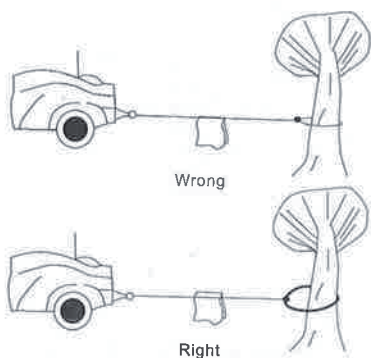

**Figure 3**

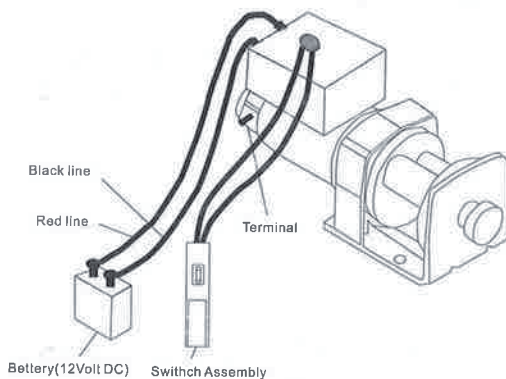

**Figure4**

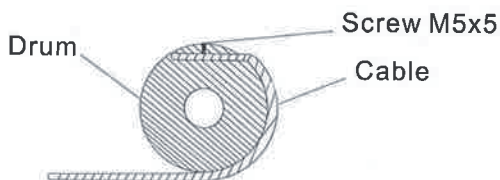

**Figure 5**



# Winch Parts List (2000lbs/2500lbs/3000lbs)

Item #	Part #	Qty	Description
1	200100	1	motor
2	200200	1	Stationary Gear Housing Assembly
3	200300	1	T-Series Carrier Assembly
4	200400	1	T-Series Rotator Gear
5	200500	1	Drum Support Plate
6	200600	4	Pan Head Screw M4x12
7	200700	1	Drum Support Bushing
8	200800	1	Clutch Assembly
9	200900	1	Spring
10	200001	1	Drum Assembly
11	200002	1	Screw M5x5
12	200003	1	T-Series Bushing
13	200004	1	Thick Flat Washer
14	200005	2	Hex Flange Nut M5
15	200006	1	T-Series Baseplate Assembly
16	200007	1	Tension Plate
17	200008	1	T-Series F/W Knob Assembly
18	200009	1	Elastic Pin 2.5x14
19	200010	2	Hex Skt FH Screw M6 x 16
20	200011	2	Screw
21	200012	2	Screw M8X30
22	200013	2	Washer-Flat 08
23	200014	2	Lock Washer 08
24	200015	2	Nut M8
25	200016	1	Safety pull strap
26	200017	1	Switch Assembly
27	200018	1	Cable Assembly
28	20019	1	Control Box

When ordering parts from this list, make sure to indicate that the part number was from the Winch Parts List.

Note: If the winch is wireless control, the switch is wireless.

# Winch Assembly Drawing

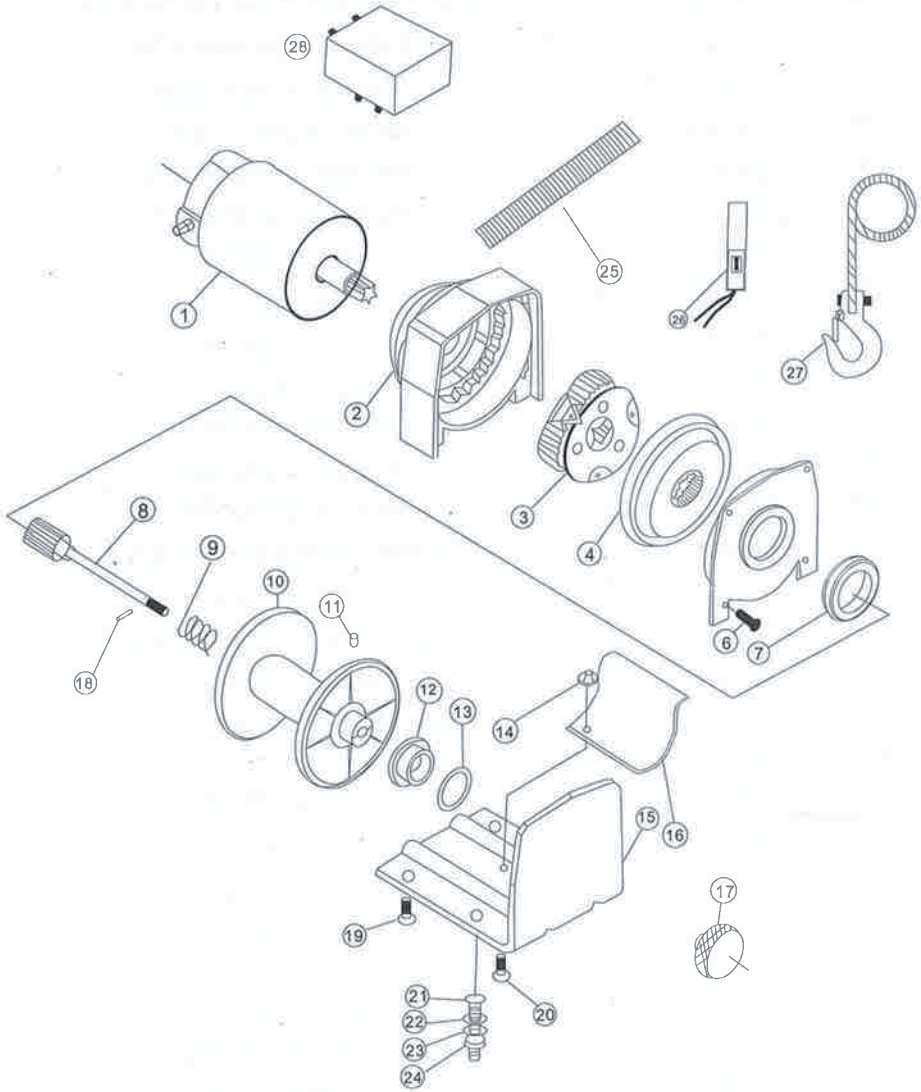

## 2000 LBS

### Performance Specifications

Single line rated pull	2000 lbs (906 kg)
Gear reduction ratio	153:1
Motor	Permanent magnet, 0.7kw/0.9hp(12V); 0.8kw/1.0hp(24V)
Overall dimensions	7.3" (L) x 4.1" (W) x 4.1" (H) 185 (L) x 105 (W) x 105 (H)mm
Drum size	∅ 12.4 (D) x 2.88" (L) ∅ 31.5 (D) x 73 (L) mm
Cable length	49ft (L) of ∅ 5/32" Cable 15m (L) of ∅ 4mm Cable
Weight	11Lbs 5kgs

### Line speed and motor current (first layer)

<b>Line pull</b>	<b>Lbs</b>	0	500	1000	1500	2000
	<b>Kg</b>	0	227	454	680	906
<b>Line Speed</b>	<b>FPM</b>	10.5	9.2	7.5	5.9	3.3
	<b>MPM</b>	3.2	2.8	2.3	1.8	1.0
<b>Motor current</b>	<b>Amps</b>	10	25	40	60	90

### Line pull and Cable capacity

<b>Layer of cable</b>		1	2	3	4	5	6
<b>Rated line pull per layer</b>	<b>Lb</b>	2000	1630	1380	1190	1050	940
	<b>Kg</b>	906	740	620	540	470	420
<b>Cable capacity per layer</b>	<b>Feet</b>	6.5	14	22	31	41	49
	<b>Meters</b>	2.0	4.3	6.8	9.5	12.5	15

## 2500 LBS

### Performance Specifications

Single line rated pull	2,500 lbs (1,133 kg)
Motor	Permanent magnet, 0.8kw/1.0hp(12v)
Gear reductin ratio	153:1
Braking action	Mechanical and Dynamic
Drum diameter	1.24"(31.5mm)
Drum length	2.88"(73mm)
Wire rope	4.76mm x 14m
Dimensions	285mm (L)x105mm(D)x103mm(H)
Mounting bolt pattern	3.13"(79.3mm)
Weight	18.7Lbs 8.5kgs

### Line speed and motor current (first layer)

Line pull	Lbs	0	500	1000	1500	2000	2500
	Kg	0	227	454	680	907	1133
Line Speed	FPM	14	12	10	8	7	5
	MPM	4.2	3.6	3.0	2.4	2.1	1.5
Motor current	Amps	20	30	55	75	100	120

### Line pull and Cable capacity

Layer of cable		1	2	3	4	5	6	7
Rated line pull per layer	Lbs	2500	2000	1630	1380	1190	1050	940
	Kg	1,133	906	740	620	540	470	420
Cable capacity per layer	Feet	4	6.5	14	22	31	41	49
	Meters	1.2	2.0	4.3	6.8	9.5	12.5	15

## 3 0 0 0 L B S

### Performance Specifications

Single line rated pull	3,000 lbs (1,361 kg)
Motor	Permanent magnet, 1.0kw/1.34hp (12V)
Gear reduction ratio	153:1
Braking action	Mechanical and Dynamic
Drum diameter	1.24"(31.5mm)
Drum length	2.88"(73mm)
Wire rope	5.4mm x 10.5m
Dimensions	12"l.x4.1"h.x4.4"d.(305mm l.x105mm h.x112mm h.)
Mounting bolt pattern	3.13"(79.3mm)
Weight	19.8Lbs 9kgs

### Line speed and Motor current (first layer)

Line pull	Lbs	0	1000	20000	3000
	Kg	0	454	907	1361
Line Speed	FPM	9.5	6.6	4.3	2.3
	MPM	2.9	2.0	1.3	0.7
Motor current	Amps	10	25	60	150

### Line pull and Cable capacity

Layer of cable		1	2	3	4	5	6
Rated line pull per layer	Lbs	3000	2370	1960	1670	1460	1290
	Kg	1,361	1075	889	756	662	585
Cable capacity per layer	Feet	5.6	12.1	19.7	27.9	37.1	46.9
	Meters	1.7	3.7	6.0	8.5	11.3	14.0