

175LB TOW BEHIND DROP SPREADER

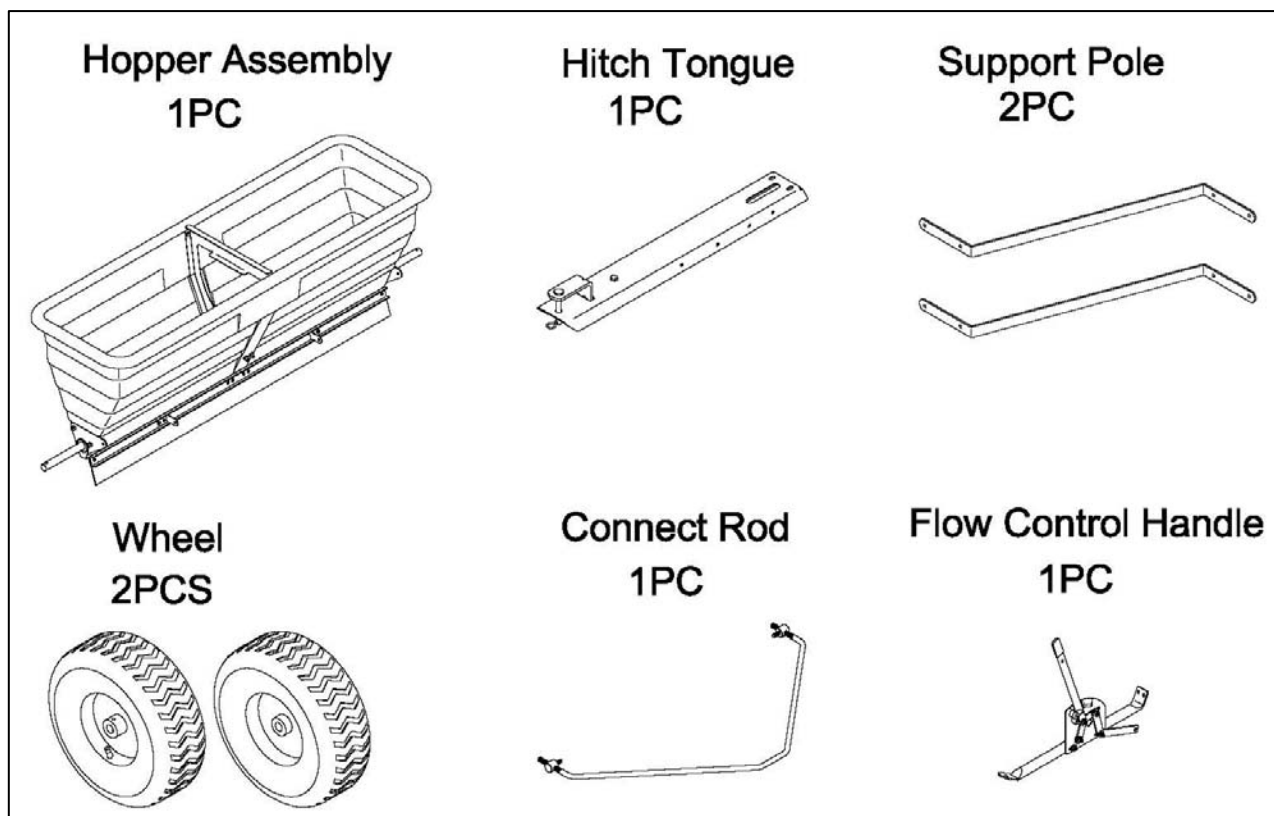

ASSEMBLY AND OPERATING INSTRUCTIONS

CARTON CONTENTS



Hardware contents please check:

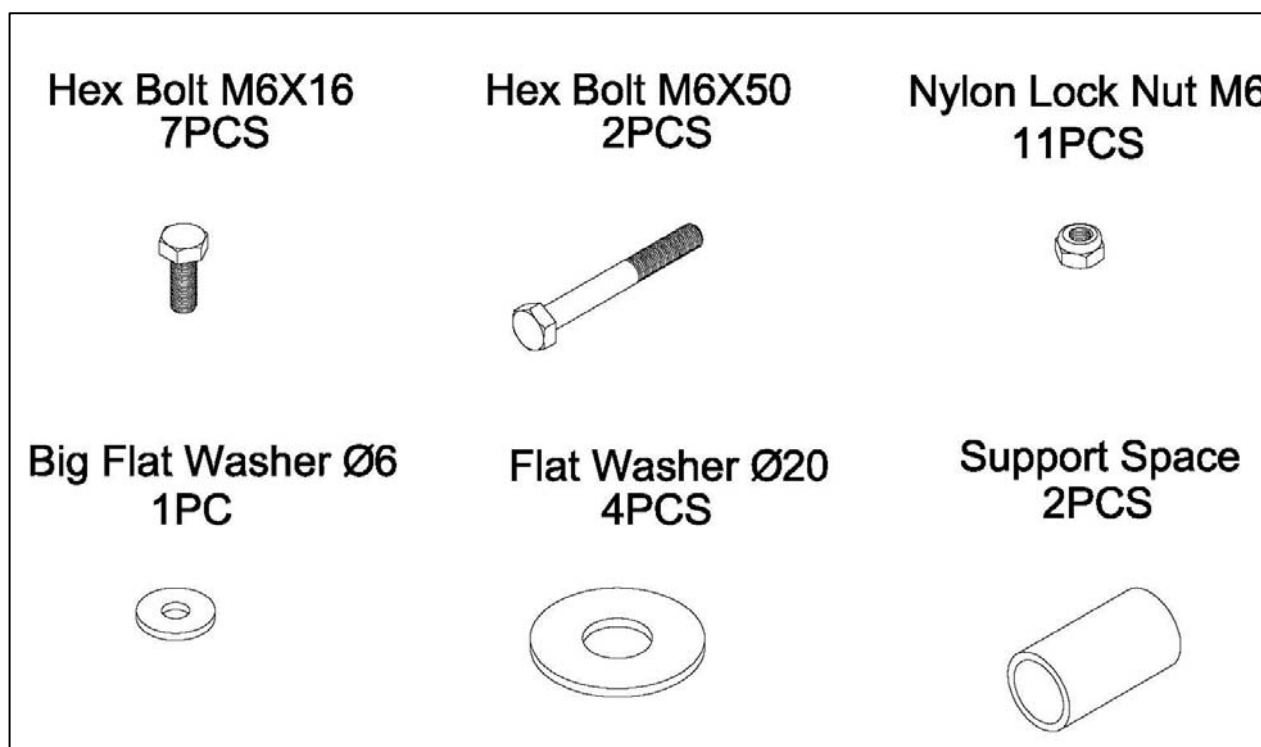

ASSEMBLY

1. Loose two Nylon Lock Nuts M6 from the hopper, then attach the Hitch Tongue to the hopper using the removed Nylon Lock Nut M6 for fixing. See Figure 1 & 2.

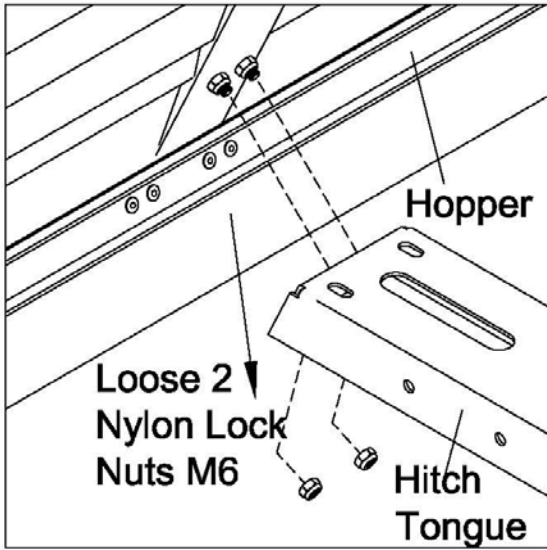

Figure 1

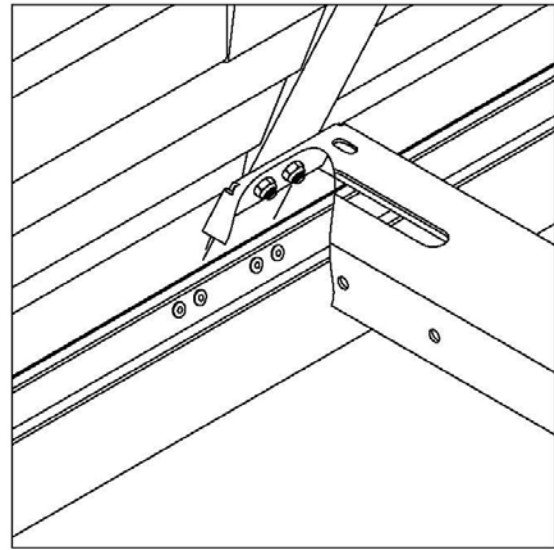

Figure 2

2. Loose one Nylon Lock Nut M6 from the hopper, assemble the Flow Control Handle to the hopper using the removed Nylon Lock Nut M6 for fixing. For the other hole on Control Handle, secure it by using one set of Hex Bolt M6x16, Big Flat Washer Ø6 and Nylon Lock Nut M6. See Figure 3 & 4. **DO NOT TIGHTEN THE BOLTS NUTS AT THIS STAGE.**

Hex Bolt M6X16

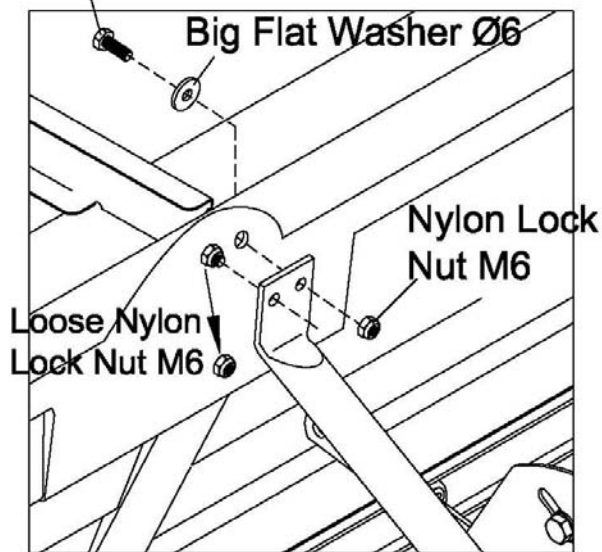

Figure 3

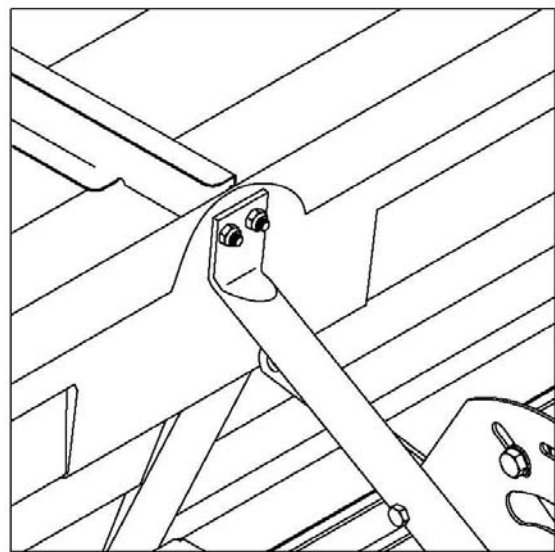

Figure 4

3. Loose the Hex Bolt M8x25 and Nylon Lock Nut M8 from the Hitch Tongue. Fix the other end of the Flow Control Handle to the hole on Hitch Tongue, fix it by using the removed Hex Bolt M8x25 and Nylon Lock Nut M8. See Figure 5 & 6.

Adjust the position of the Flow Control Handle, then tighten the bolts and nuts in Figure 4 & 6.

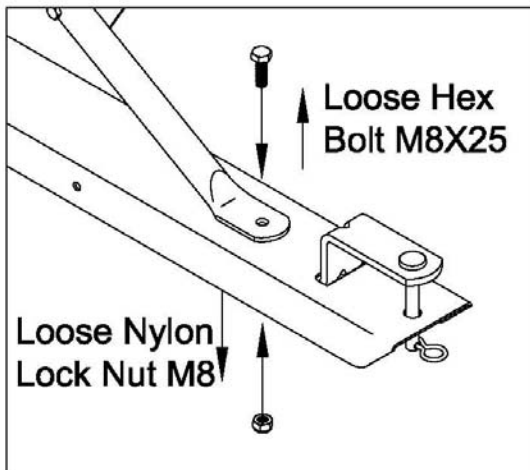

Figure 5

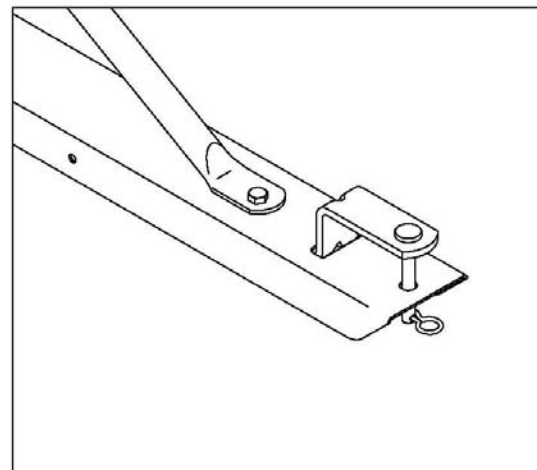

Figure 6

4. Loose one Connect Screw from the Connect Rod. See Figure 7.

Insert the Connect Rod to the hole below the Flow Control Handle fix with the Connect Screw. See Figure 8.

Attach the Connect Screw on two end of Connect Rod to the Fix Bracket on Dodge Gate, secure by Nylon Lock Nut M6. Do not secure the nuts too tight, the connect screw can rotate by itself. See Figure 9 & 10.

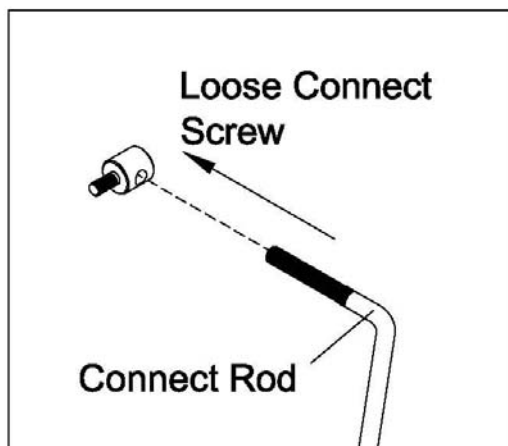

Figure 7

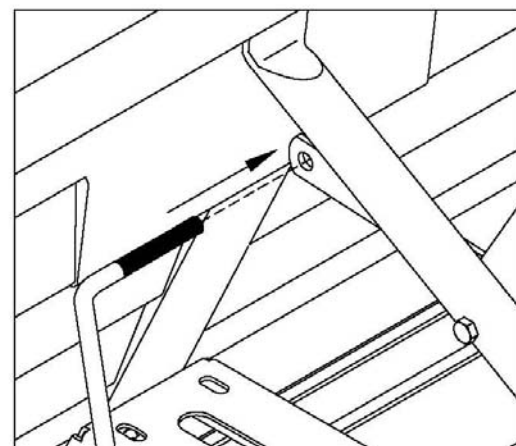

Figure 8

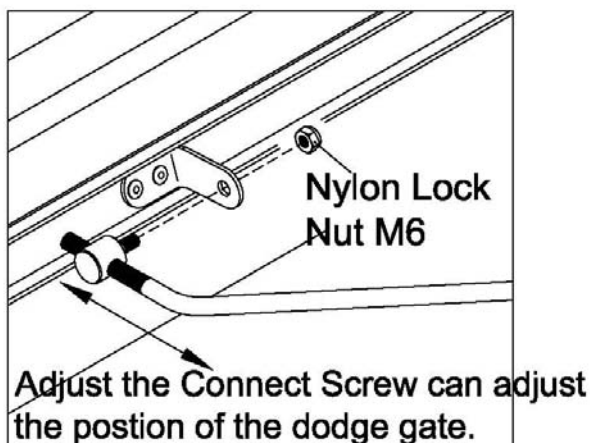

Figure 9

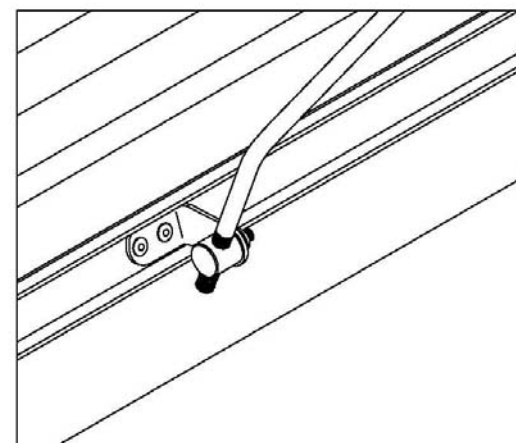

Figure 10

5. Loose one Nylon Lock Nut M6 from the hopper (show with the arrow), then fix one end of Support Polo to the bolt on hopper, then secure the support polo with the removed Nylon Lock Nut M6. Fix another hole on Support Polo with the hopper by using a Hex Bolt M6x16 and Nylon Lock Nut M6. See Figure 11. Do not TIGHTEN the bolts and nuts.

Fix the other end of Support Polo to the Hitch Tongue by using two Hex Bolt M6x16 and Nylon Lock Nut M6. Do not TIGHTEN the bolts and nuts. See Figure 12.

Assemble the other support polo in same way. Then adjust the position of Hitch Tongue and Support Polo, then tighten all the bolts and nuts.

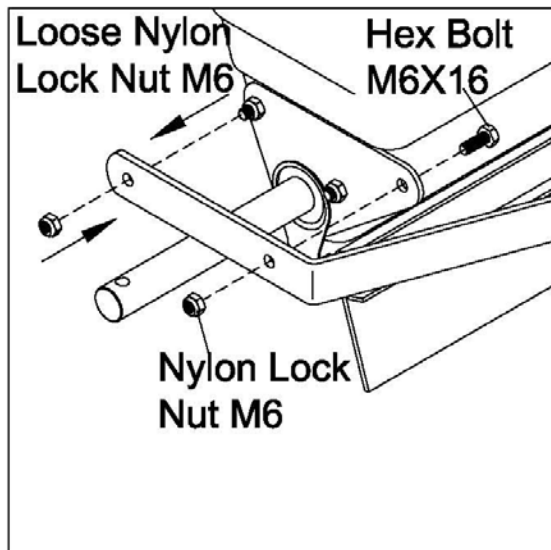

Figure 11

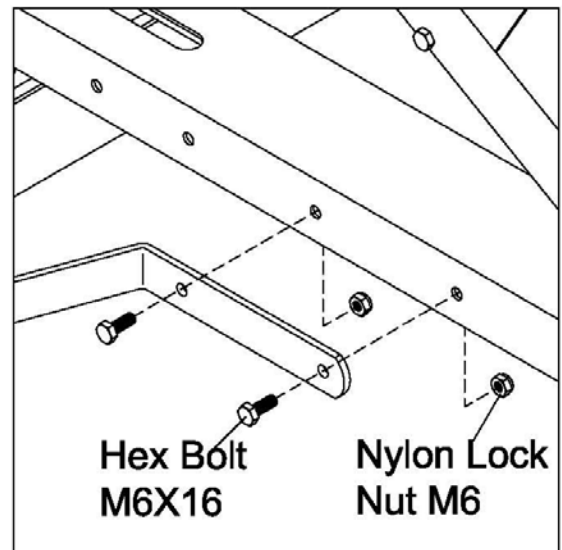

Figure 12

6. On the wheel axle, insert the Flat Washer Ø20, Support Space, Flat Washer Ø20, and Wheel by Sequence. (Note the valve on wheel should be in outside). See Figure 13.

Make sure the hole on Wheel Hub and Wheel Axle are in alignment. Secure the wheel by using one Hex Bolt M6x50 and Nylon Lock Nut M6. See Figure 14.

Assemble another wheel in same way.

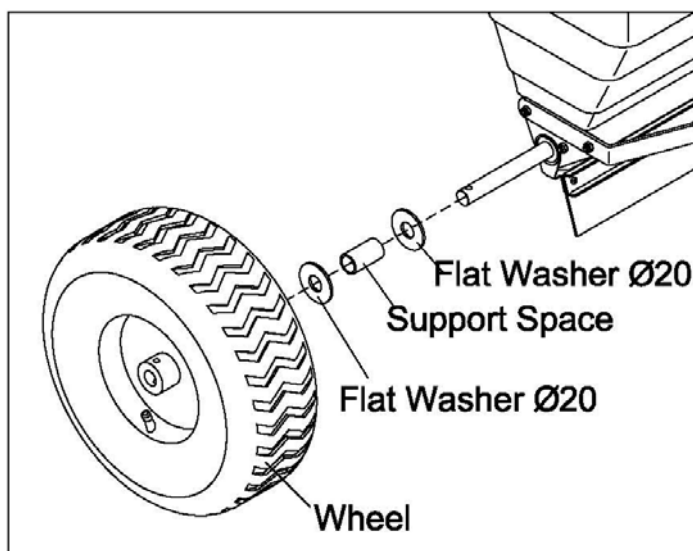

Figure 13

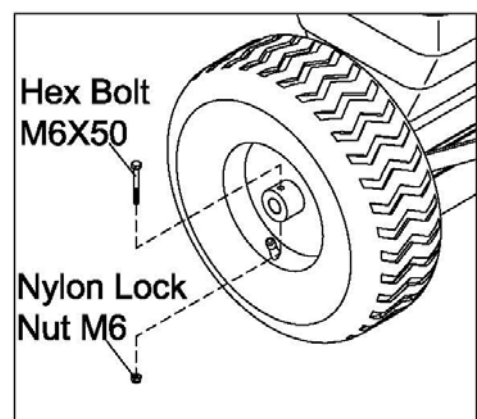
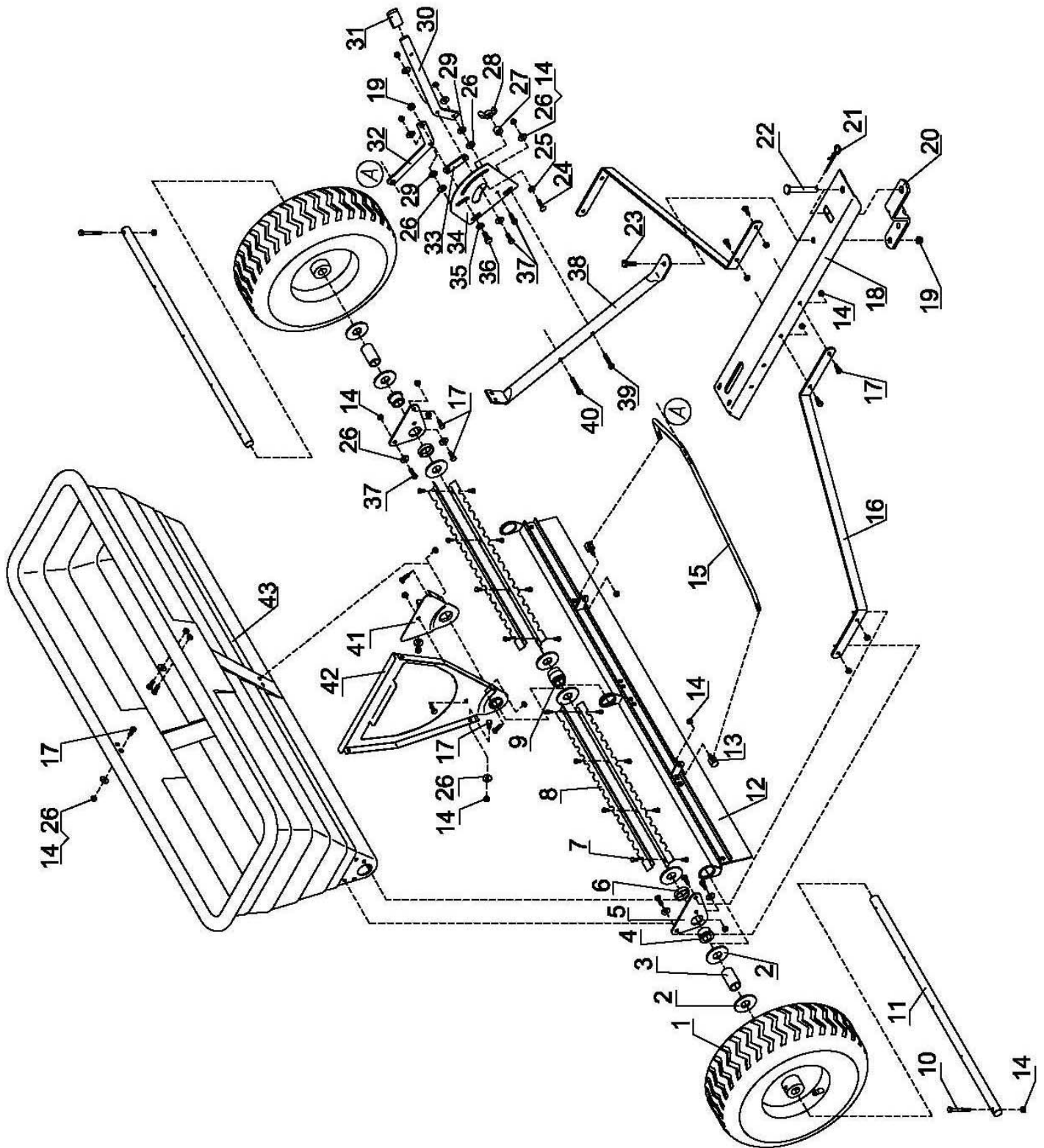

Figure 14

EXPLODED DRAWING



PARTS LIST

Part#	Description	Qty	Part#	Description	Qty
1	Wheel	2	23	Hex Bolt M8x25	1
2	Flat Washer Ø20	8	24	Carriage Bolt M6x25	1
3	Support Space	2	25	Teeth Lock Washer Ø8	1
4	Bushing	2	26	Big Flat Washer Ø6	15
5	Fix Bracket	2	27	Spacer	1
6	Short Spacer	2	28	Wing Nut M6	1
7	Hex Bolt M5x10	16	29	Nylon Washer	2
8	Agitator Blade	4	30	Adjustable Handle	1
9	Middle Bushing	1	31	Handle Grip	1
10	Hex Bolt M6x50	2	32	Control Rod	1
11	Wheel Axle	2	33	Flow Control Plate	1
12	Dodge Gate	1	34	Gauge Plate	1
13	Connect Screw	2	35	Flat Washer Ø8	1
14	Nylon Lock Nut M6	26	36	Hex Bolt M8x20	1
15	Connect Rod	1	37	Hex Bolt M6x20	4
16	Support Polo	2	38	Support Polo	1
17	Hex Bolt M6x16	16	39	Hex Bolt M6x35	1
18	Hitch Tongue	1	40	Hex Bolt M6x45	1
19	Nylon Lock Nut M8	2	41	Small Bracket	1
20	Hitch Bracket	1	42	Middle Bracket	1
21	R Pin Ø3x75	1	43	Hopper	1
22	Male Pin	1			