

# 80LB WALK BEHIND SPREADER

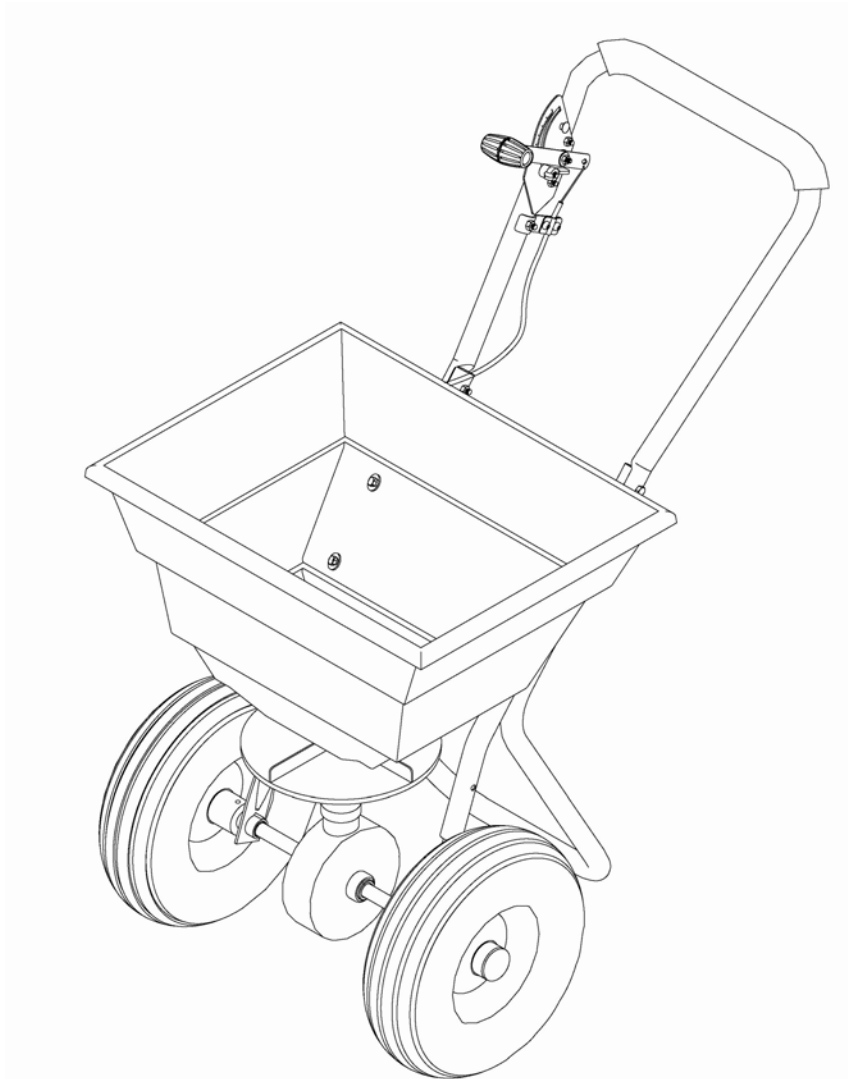

## Assembly and Operating Instructions

### 1. HELPFUL HINTS:

#### READ THE INSTRUCTIONS BEFORE ASSEMBLY

- If your spreader does not spread evenly, be sure the FRONT on the gear box points to the front of the spreader. The impeller must turn clockwise. Reversing the gear box will cause the impeller to turn counter clockwise. Clean the impeller plate after each use. Fertilizer stuck on the impeller blades will cause uneven spreading.
- Your spreader is designed to be pushed at three miles per hour, which is a brisk walking speed. Slower or faster speeds will change the spread patterns. Wet fertilizer will also change the spread pattern and flow rate. Clean your spreader thoroughly after each use. Wash between the shut off plate and bottom of the hopper.
- Gears are permanently lubricated at the factory. Do not open the gear box or dirt may enter.

**2. Remove and identify loose parts from carton and bag.**

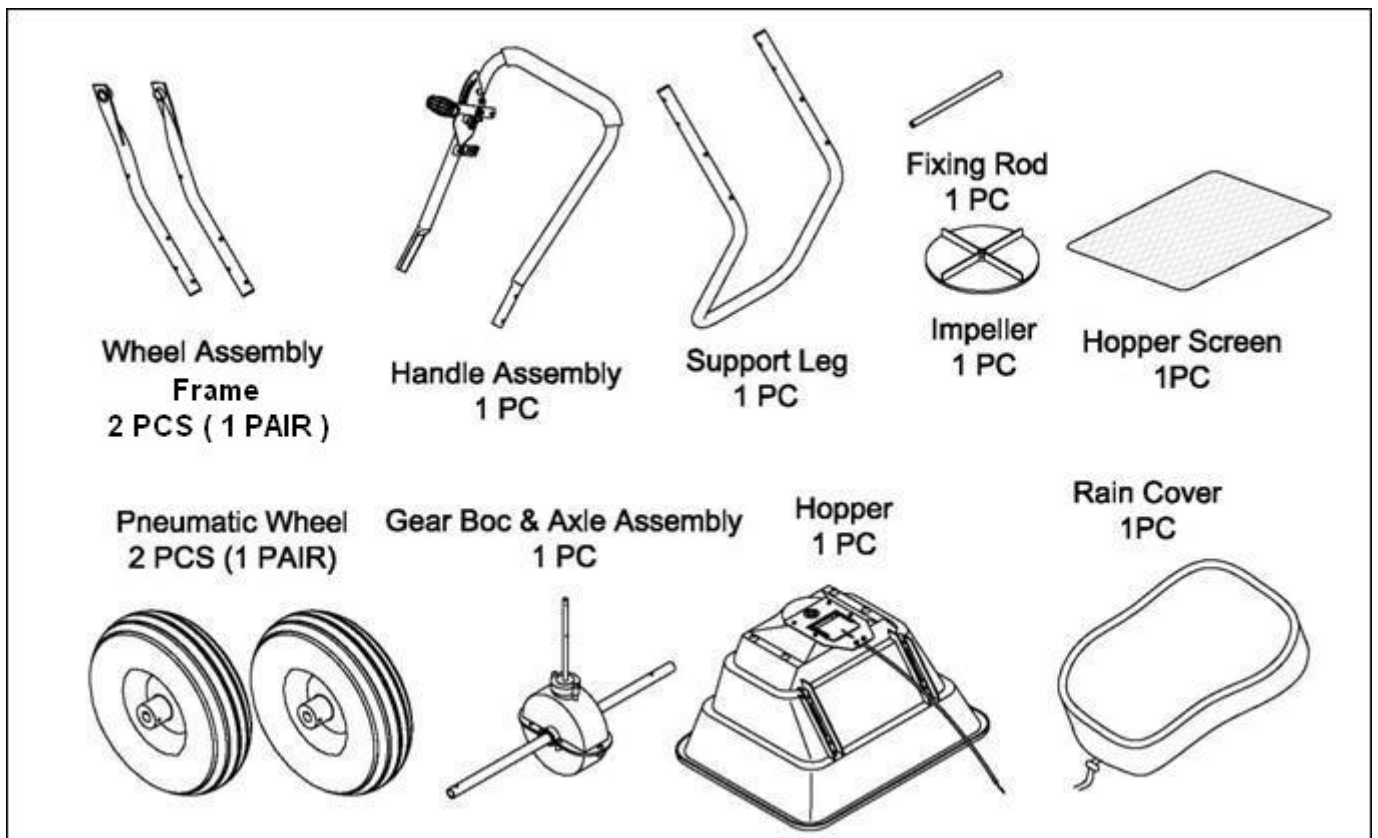
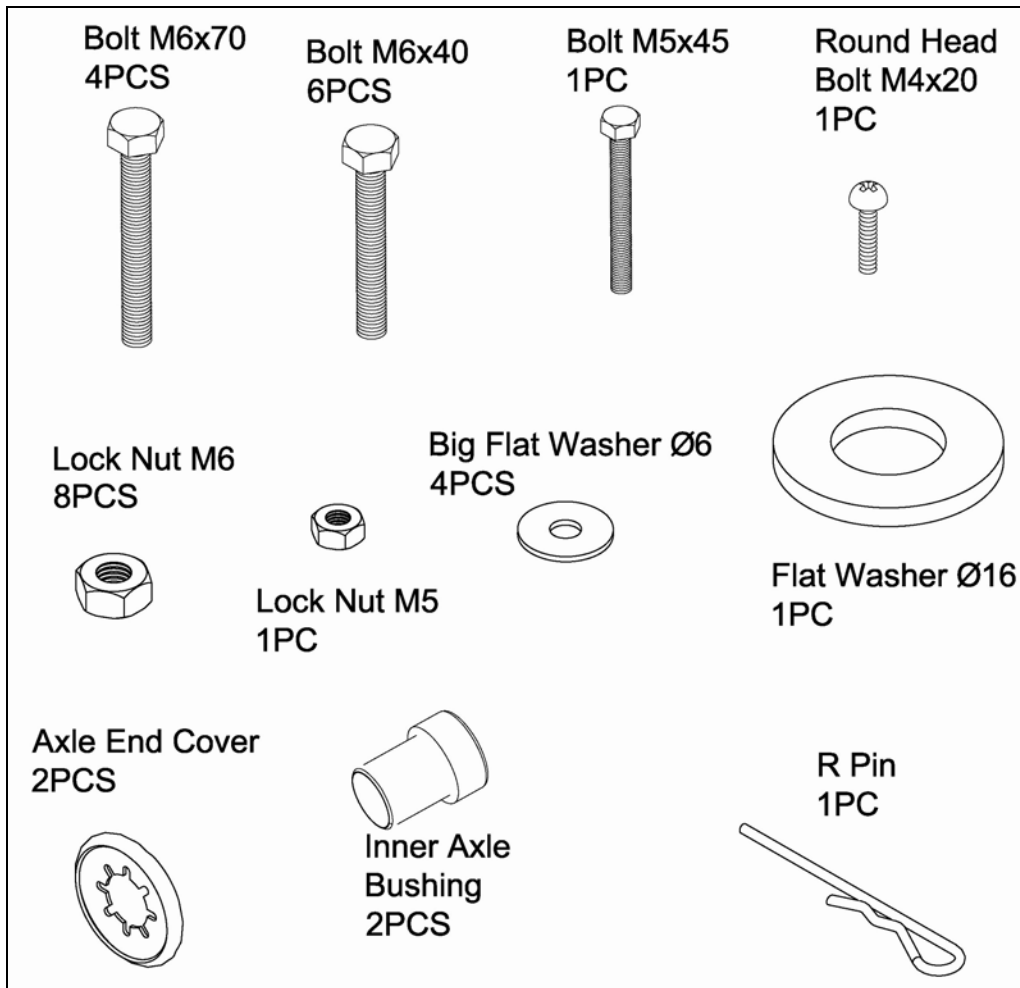

**STEP 1:** Install impeller onto the Gear Box & Axle Assembly. Insert Screw M4x20 through impeller then through Gear Box Axle.

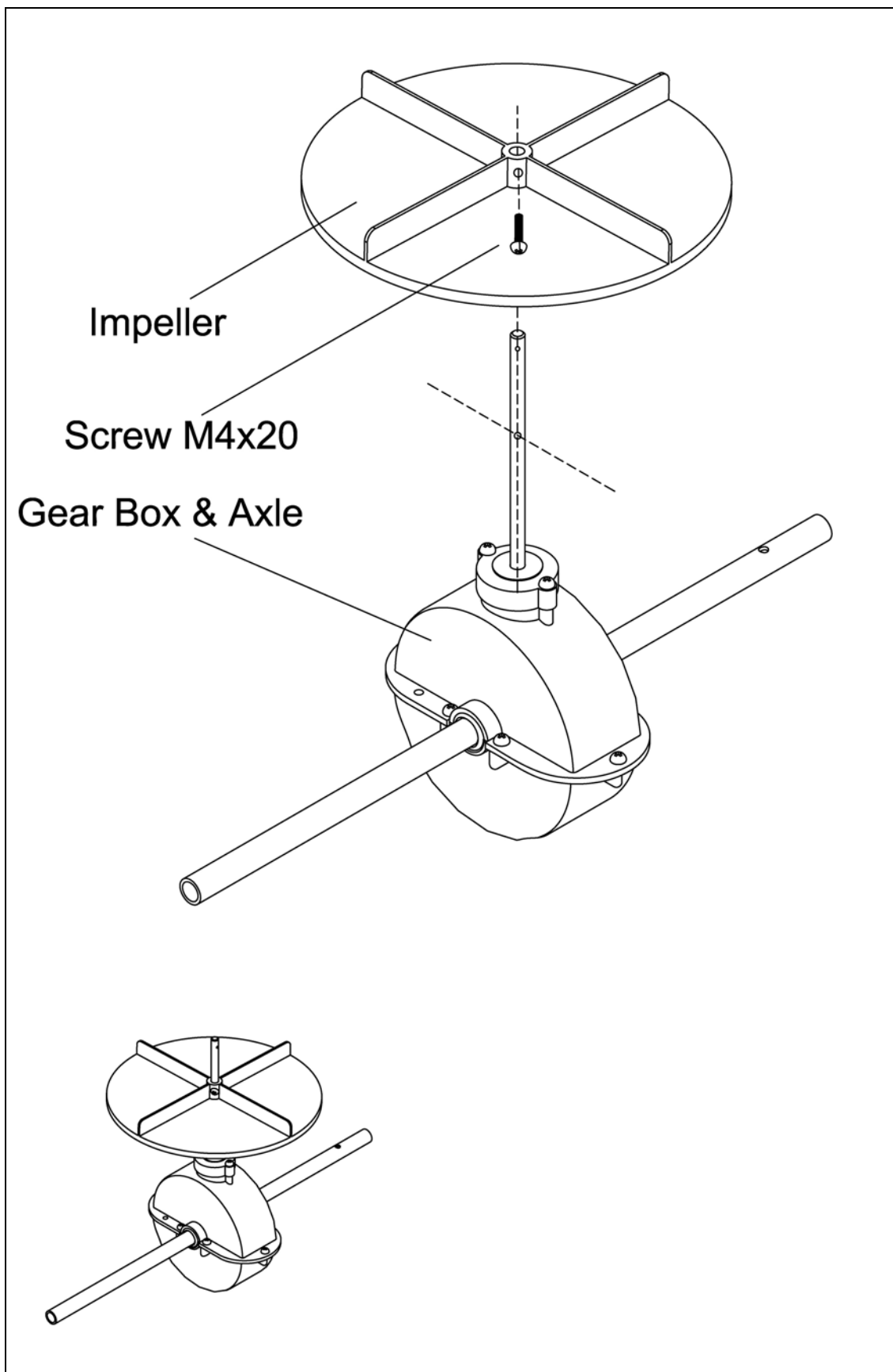

**STEP 2:** Attach the Wheel Assembly Frame on each side of the Gear Box Axle and Fixing Connecting Rod, insert two bolts M6x40 into the Fixing Connecting Rod through Wheel Assembly Frame. Make sure the hole on Axle of Gear Box is on the right side when assembly as shown. Attach Wheel Assembly Frames and Support Leg onto Hopper using bolts M6x70, lock nuts M6 and Big Flat Washers Ø6. Note: The bolts and nuts needn't be tightened yet.

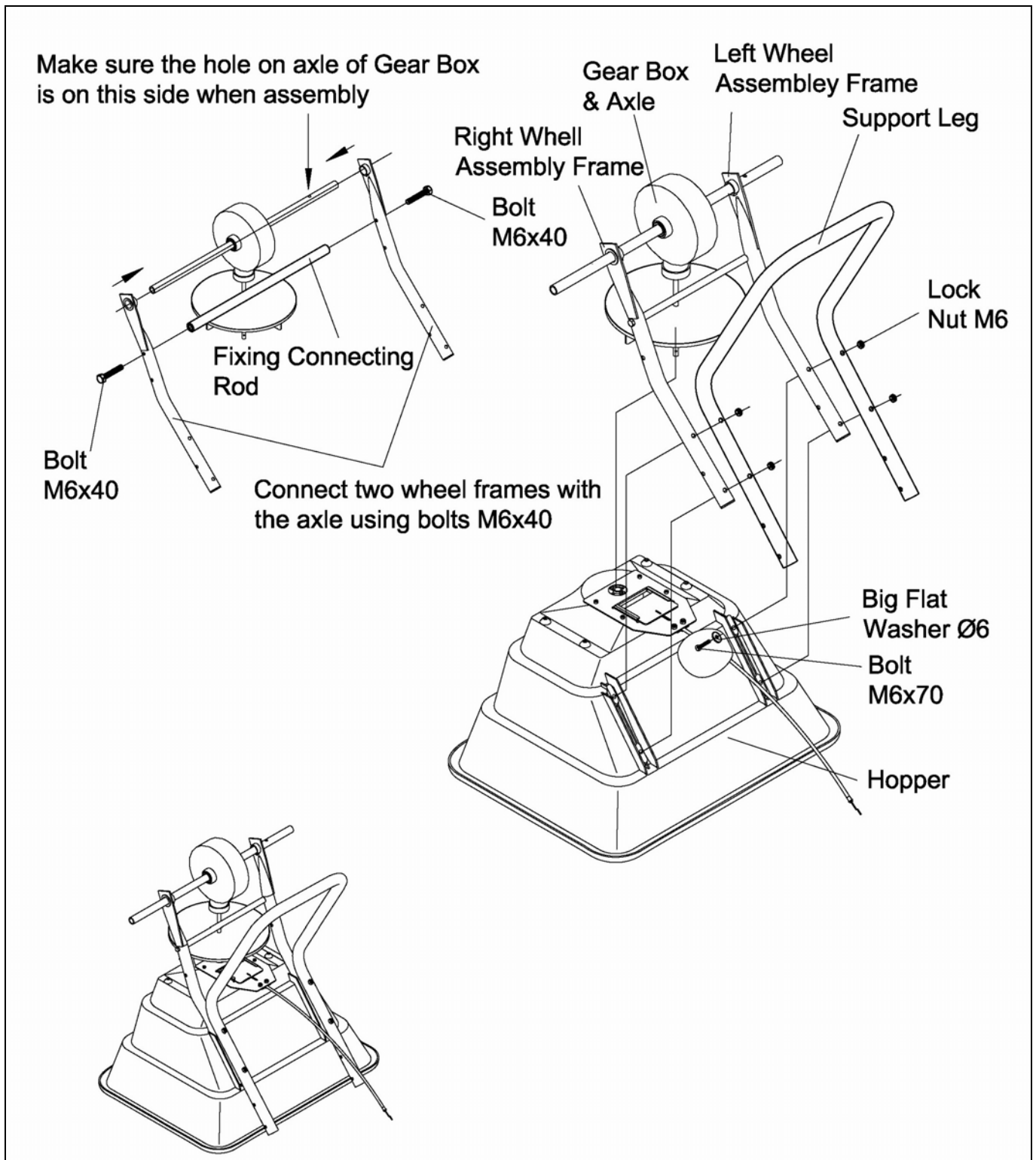

**STEP 3:** Insert Inner Axle Bushing into Outer Axle Bushing and make sure they are tight neatly. Install right Wheel Assembly to right Axle using bolt M5x45 and lock nut M5, and then install the Cap onto right Axle using a wooden or rubber hammer. Now install left Wheel Assembly to left Axle, put a flat washer Ø16 and install the Cap onto left Axle using a wooden or rubber hammer.

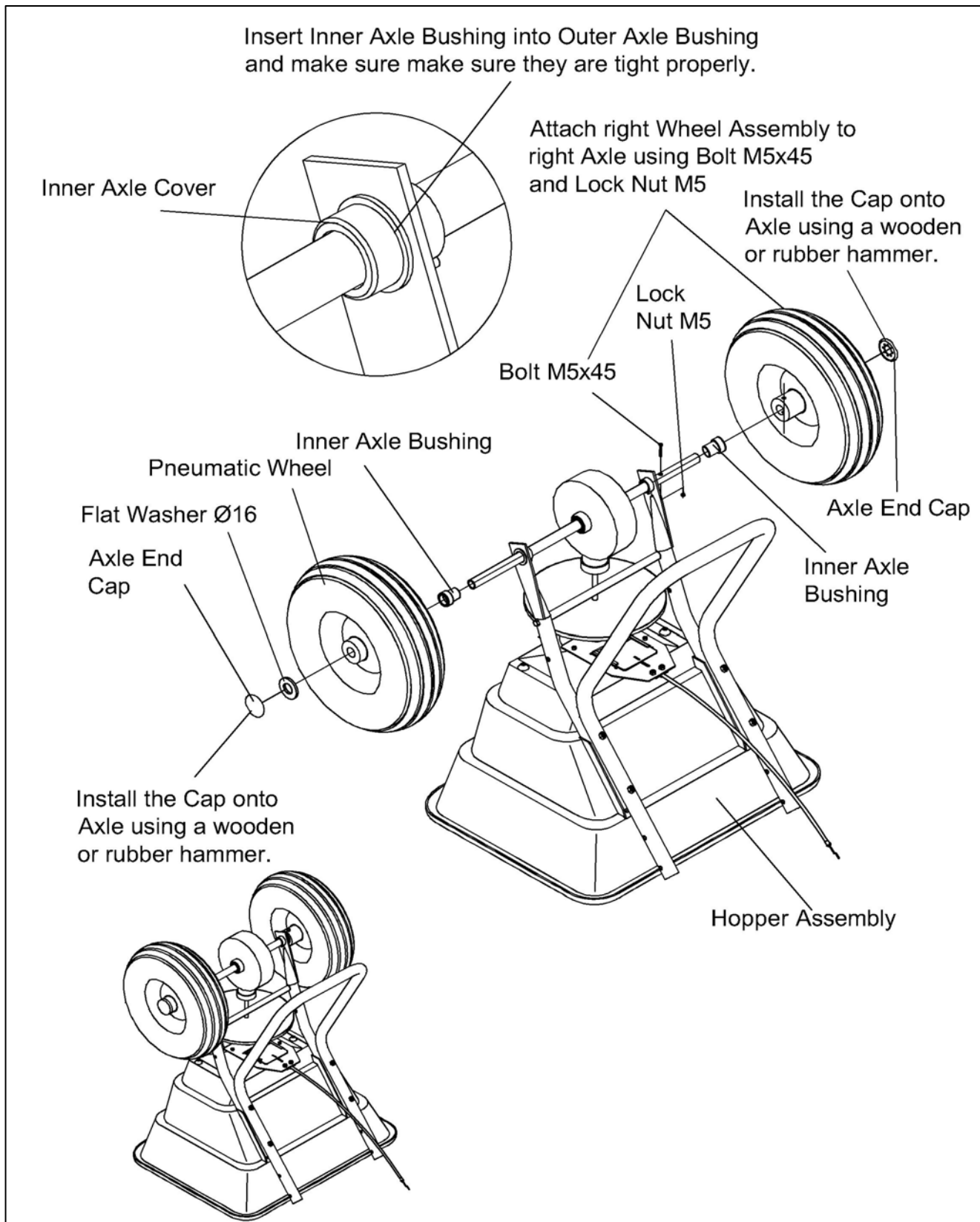

**STEP 4:** Insert Upper Handle into the Support Leg and tighten using bolts M6x40 and Lock Nuts M6. **NOW GO BACK AND TIGHTEN ALL NUTS AND BOLTS STARTING WITH FIRST STEP. DO NOT OVER TIGHTEN.**

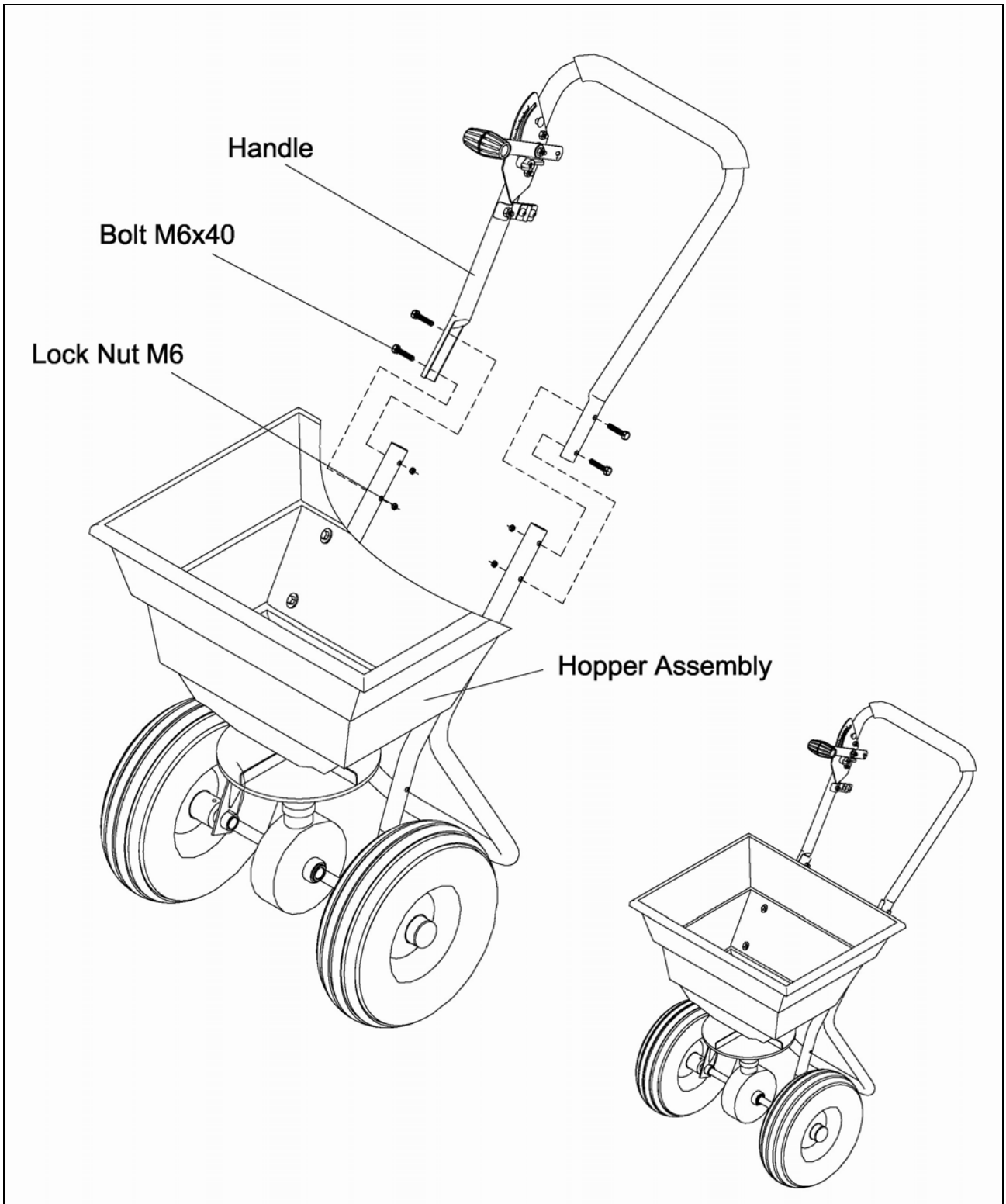

**STEP 5:** (1) Insert the Steel Wire head of control cable into the small hole on Gauge and Lever Assembly. (2) Release two bolts M5x10 and lock nuts on Press Plate. (3) Put the Plastic Tube into the slot of Press Plate. (4) Tighten two bolts M5x10 and lock nuts again. (5). Insert R Pin.

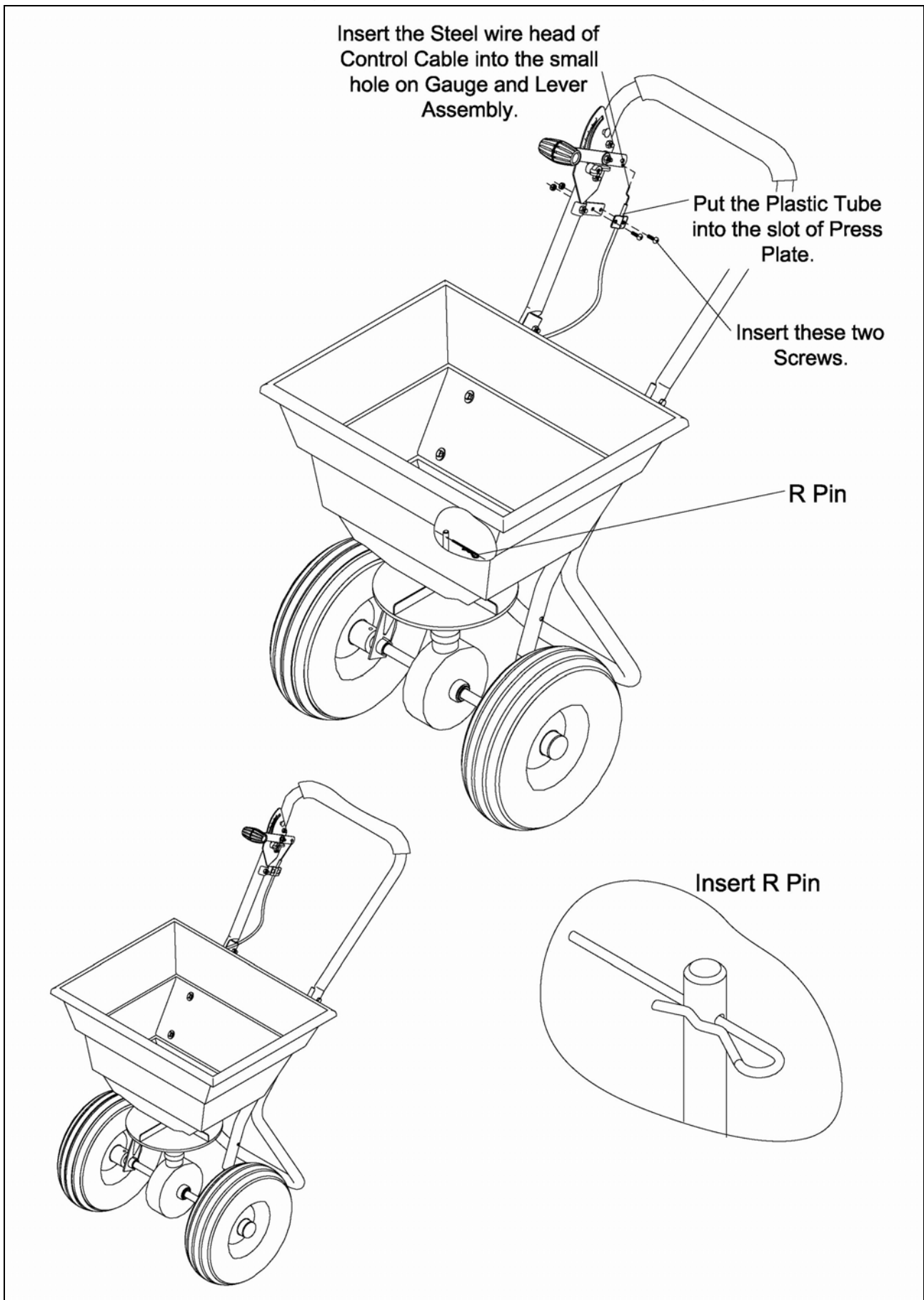

**STEP 6: ADJUSTMENTS.** When you have finished all above steps, and if you find the holes at the bottom of hopper can close and open completely by using the handle . You don't need to do the following steps. If it do not close and open completely, you may need to do the following steps. (1)Release two bolts M5x10 on clamp as shown. (2). Push the handle to the top position, use your hand to adjust the adjustable plate so as to make sure the hole at the bottom of hopper can be closed completely. (3). Push the handle to the lowest position, use your hand to adjust the adjustable plate so as to make sure the hole at the bottom of hopper can be opened completely. (4). And then tighten the bolts and nuts on clamp again. **To operate this spreader, push the handle to the lowest position (downwards).** You may move the position of Wing nut on the Gauge & Lever to adjust the space on the hole between the hopper and the adjustable plate as per your need when spreading.

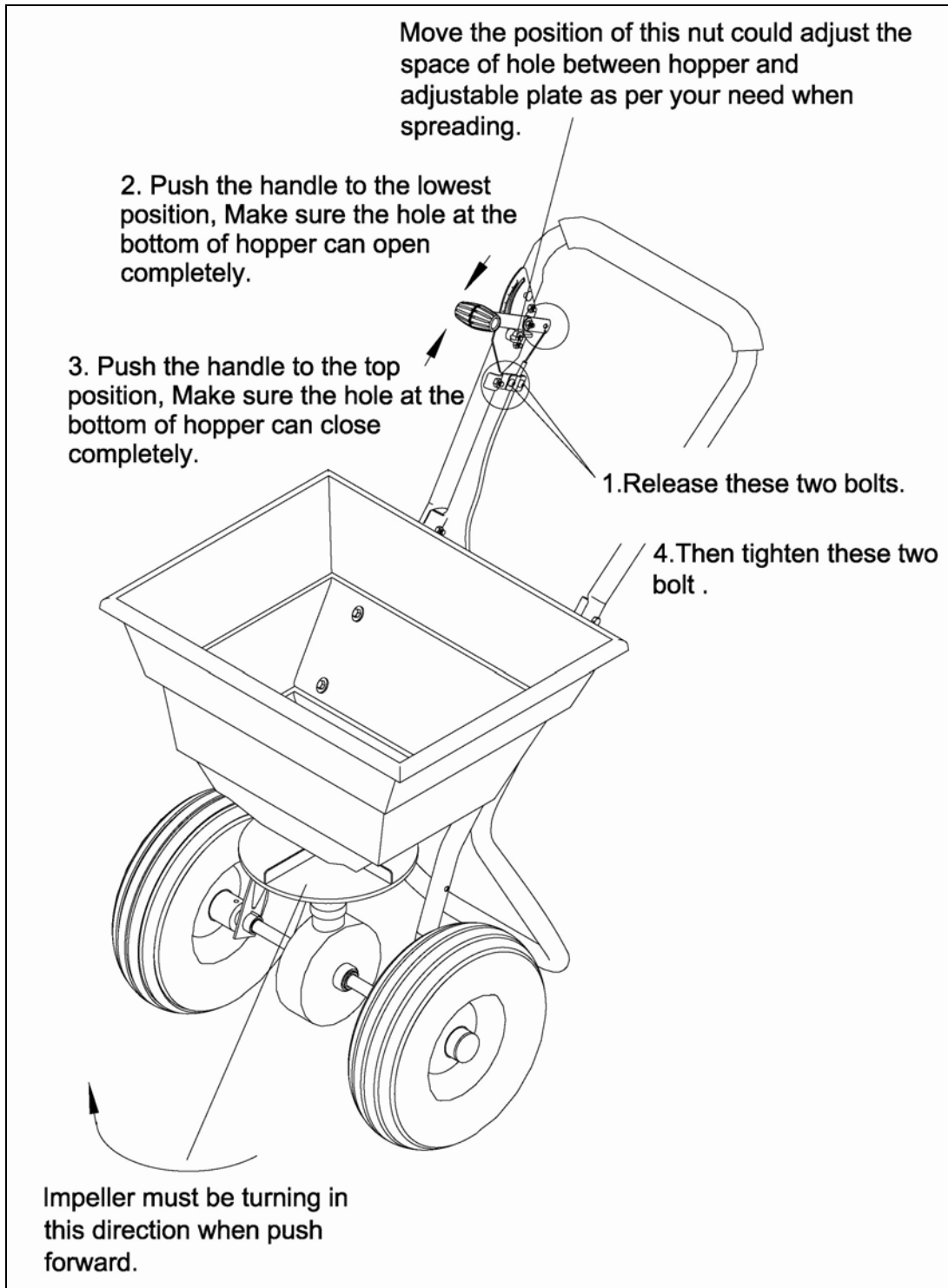



# PARTS DRAWING

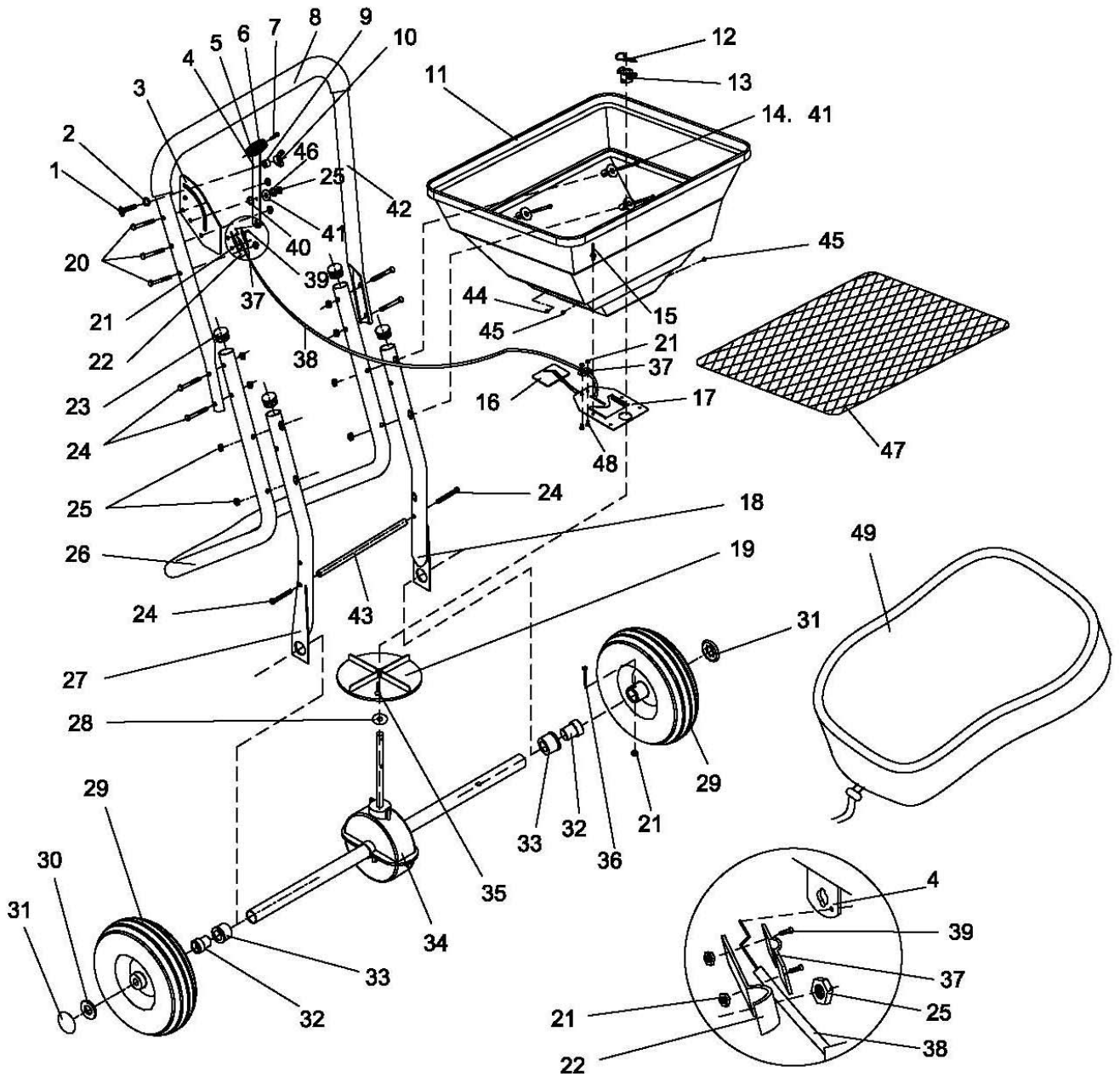

## PARTS LIST

Ref#	Description	Qty	Ref#	Description	Qty
1	Carriage Bolt M6x25	1	26	Support Leg	1
2	External-tooth Washer Ø8	1	27	Wheel Assembly Frame(Right)	1
3	Gauge and Lever Assembly	1	28	Thin Washer	1
4	Adjust Handle Pole	1	29	Pneumatic Wheel	2
5	Adjust Handle A	1	30	Flat Washer Ø16	1
6	Adjust Handle B	1	31	Axle End Cover	2
7	Screw M4x18	1	32	Inner Axle Bushing	2
8	Handle Grip	1	33	Outer Axle Bushing	2
9	Spacer	1	34	Gear Box & Axle Assembly	1
10	Wing Nut	1	35	Screw M4x20	1
11	Hopper	1	36	Hex Bolt M5x45	1
12	R Pin Ø2x60	1	37	Line Clamp Press Plate	2
13	Center Cover	1	38	Control Rod	1
14	Hex Bolt M6x70	4	39	Screw M5x10	2
15	Rivet Ø5X12	4	40	Nylon Washer	1
16	Active Adjustable Plate	1	41	Big Flat Washer Ø6	5
17	Fixed Adjustable Plate	1	42	Handle	1
18	Wheel Assembly Frame(Left)	1	43	Fixing Connection Rod	1
19	Impeller	1	44	Big End Cap	1
20	Hex Bolt M6x35	3	45	Small End Cap	2
21	Lock Nut M5	5	46	Lock Washer Ø6	1
22	Line Clamp Bottom Plate	1	47	Hopper Screen	1
23	Tube End Cap	4	48	Screw M5x12	2
24	Hex Bolt M6x40	6	49	Rain Cover	1
25	Lock Nut M6	12			